

MR Flow Transmitter Installation & Maintenance Instructions

HEDLAND
DIVISION OF RACINE FEDERATED INC.

FORM #HLIT 306

8635 Washington Avenue • Racine • Wisconsin 53406-3738
TEL 1-800-HEDLAND • FAX 1-800 CHK-FLOW

I. INTRODUCTION

The MR Flow Transmitter is a state-of-the-art, microprocessor based variable area flow meter. It combines the rugged proven technology of a piston-type, variable area flow meter with solid state circuitry including:

- Non-contact sensor electronics
- Electronic signal conditioning circuit
- Digital flow rate and total indication
- Proportional analog output

The product is sealed against industrial contamination by a NEMA 12 and 13 (IP 52/54) rated enclosure and is available for either liquid or gas service.

The MR Flow Transmitter is capable of calculating and displaying both flow rate and total accumulated flow. The flow rate and total flow can be displayed in any of the user selectable measurement units. The monitor's large 8 digit numeric liquid crystal display makes extended range viewing practical. The second 8 character alphanumeric display provides for selectable units viewing in RUN mode and prompts for variables in PROGRAM mode.

All MR Flow Transmitters come pre-calibrated from the factory. However, the unit may be adjusted by the user to meet specific system requirements. Calibration parameters are included for:

- Specific gravity compensation (all fluids)
- Viscosity compensation (petroleum-based fluids)
- Pressure and temperature compensation (pneumatic applications)



US Patent 7,130,750

Figure 1 - MR Flow Transmitter

All meters include an analog output that can be configured for 0-5 Vdc, 0-10 Vdc, or 4-20 mA current loop.

Applications for the MR Flow Transmitter include:

- Bearing lubrication
- Case drain verification
- Gun drill and machine cooling
- Pump flow outputs

II. SPECIFICATIONS

Enclosure Rating

- NEMA 12 & 13 (IP 52 & 54)

Operating Temperature

- Fluid: -20 °F to +240 °F (-29 °C to +116 °C)
- Ambient: -20 °F to +158 °F (-29 °C to +70 °C)

Environmental

- Humidity: 0-90% non-condensing

Pressure Rating Aluminum/Brass

- Liquids (¼" to 1-½"): 3500 psi (241 bar) maximum with a 3:1 safety factor
- Gases (¼" to 1-½"): 1000 psi (69 bar) maximum with a 10:1 safety factor

Pressure Rating Stainless Steel

- Liquids (¼" to ½"): 6000 psi (414 bar) maximum with a 3:1 safety factor
- Liquids (¾" to 1-½"): 5000 psi (345 bar) maximum with a 3:1 safety factor
- Gases (¼" to 1-½"): 1500 psi (103 bar) maximum with a 10:1 safety factor

Accuracy

- ±2% of full scale

Repeatability

- ±0.5%

Pressure Drop

- See Appendix for specific meter information

Electrical

Power Requirement:

- 0-5 Vdc Output 10-30 Vdc @ 0.75W maximum
- 0-10 Vdc Output 12-30 Vdc @ 0.75W maximum
- 4-20 mA Output loop-powered, 30 Vdc maximum

Power Consumption:

- 25 mA maximum

Analog Outputs:

- 0-5 Vdc and 0-10 Vdc into 10,000 Ohms minimum
- 4-20 mA into 1000 Ohms maximum (see **Figure 2**)

Circuit Protection:

- Reverse polarity and current limiting

Transmission Distance:

- 4-20 mA limited by cable resistance
- 0-5 Vdc 1000 feet (300 m) maximum
- 0-10 Vdc 1000 feet (300 m) maximum

Isolation:

- Inherently isolated from the piping system

Rate and Totalization Display

- Fixed or toggle modes of operation for rate and totalizer display
- 8 digit, .70" high numeric display for rate and total
- 8 digit, .34" high alphanumeric display for units and setup

Temperature Drift

- 50 ppm / °C (maximum)

Analog Output

- Resolution - 1:4000

Compliance

- Meets the requirements of EN61000-6-4 for a Class A product for emissions and EN61000-6-2 for immunity tests of an ISM product.

Dimensions

- See Appendix

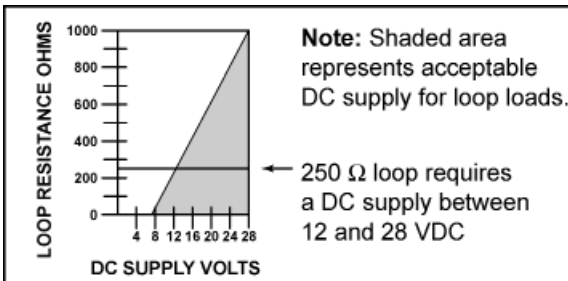

Figure 2 - Load Limitations (4-20 mA only)

III. INSTALLATION

CAUTION

This product should be installed and serviced by technically qualified personnel trained in maintaining industrial class flow instrumentation and processing equipment.

CAUTION

Read instructions thoroughly before installing the unit. If you have any questions regarding product installation or maintenance, call your local supplier for more information.

WARNING

Disconnect electrical power before opening wiring enclosure. Failure to follow these instructions could result in serious personal injury or death and/or damage to the equipment.

WARNING

All wiring should be installed in accordance with the National Electrical Code® and must conform to any applicable state and local codes. Failure to follow these instructions could result in serious personal injury or death and/or damage to the equipment.

CAUTION

Air/gas meters are NOT oxygen cleaned. Use with oxygen may cause hazardous or explosive conditions that may cause serious personal injury and/or damage to the equipment.

CAUTION

This meter may contain residual amounts of test fluid at the time of shipment. This fluid should be removed prior to installation as the fluid may be incompatible or hazardous with some liquids or gases. Failure to follow these instructions could result in damage to the equipment.

CAUTION

This standard meter is unidirectional. Attempts to flow fluids in the opposite direction of the flow arrow will result in the meter acting as a check valve, creating a deadheading situation. If the differential pressure magnitude is great enough, damage to the internal parts of the meter will result.

Installation Recommendations

The transmitter is a simple device to install. However, the following measures are recommended for reliable, trouble-free operation:

Do - Align pipe accurately. Piping should be accurately aligned and of correct length. The high pressure body of the transmitter can withstand shock and flow/pressure pulsation. However, the piping should be firmly supported by external mounting brackets, both upstream and downstream of the meter, to avoid any pipe flexing actions that could reduce meter life.

Do - Use rigid mounting. If the transmitter inlet or outlet are to be rigidly mounted, and the opposing port is to be connected to flexible hose, the end connected with the flexible hose must be rigidly mounted.

Do - Use Teflon® tape for sealing NPT fitting.

Do - Install unions. Install a union near the inlet or outlet of the transmitter. This will facilitate quick, easy meter removal and inspection during periodic maintenance procedures.

Do - Ensure the fluid is traveling in the direction of the flow arrow (**Figure 5** on page 6).

NOTE: The MR Flow Transmitter display board can be rotated 180° for optimal viewing. Simply remove the MR Flow Transmitter cover, disconnect the ribbon cable, rotate the display board 180°, reconnect the ribbon cable, and reinstall cover. See **Figure 8** on page 8 for cover screw tightening sequence.

Do - Use at least a 200 mesh (74 micron) filter. The transmitter will allow particulate to pass that would jam most valves and flow controls. Systems that do not have filtration should be equipped with at least a 200 mesh (74 micron) filter. Most hydraulic systems already have much finer filtration.

Dirt, ferrous metal or sealing agents, such as Teflon® tape may lodge and cause malfunction. If the meter is jammed at a fixed position, follow cleaning and maintenance instructions.

Don't - Use thread locking compounds as thread sealant.

Don't - Install the transmitter near turbulence producing fittings such as elbows, reducers, close coupled valves, etc. The transmitter does not require flow straighteners or special lengths of straight inlet/outlet piping to stabilize turbulent flow patterns. However, to assure maximum operational reliability, avoid installation of elbows, valves and/or reducers immediately adjacent to the meter inlet.

Don't - Install the transmitter near fast-acting valves. Fast-acting valves have the potential to create high magnitude hydraulic pressure spikes. These spikes can damage the internal components of the meter, resulting in inaccuracies or malfunction.

Don't - Allow unidirectional transmitters to be operated against the direction of the flow arrow. The standard transmitter is a unidirectional flow meter. The piston acts as a check valve to block flow in the reverse direction. This causes an excessive pressure differential, which can result in damage to internal meter components. The transmitter is also available in a modified design, which offers a reverse flow by-pass feature to accommodate bi-directional flow.

NOTE: Transmitters with a reverse flow by-pass feature are available. Consult factory for details.

Electrical Connections

Cable may be shortened or lengthened as required by installation. The cable is soldered directly to the electrical connector at the factory.

Cable replacement requires disassembly of the electrical connector.

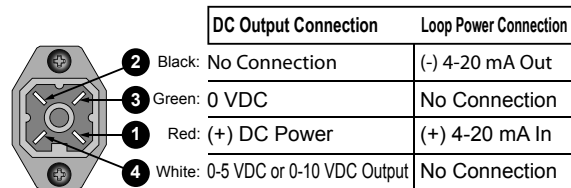

Figure 3 - Electrical 4-Pin Connection



CAUTION

The flow transmitter is designed to operate only one of its three outputs at a time (i.e., 0-5 Vdc or 0-10 Vdc or 4-20 mA). Connecting multiple outputs simultaneously will result in inaccurate output signal levels.

Schematics

The transmitter can be wired in various configurations to allow interface with many different types of data collection and control instrumentation.

Schematics 1 & 2 represent typical wiring for a target powered by either AC power or DC supply.

Schematics 3 & 4 will be utilized when the flow transmitter is operated with loop-powered process indicators or data loggers that do not have external sensor excitation available.

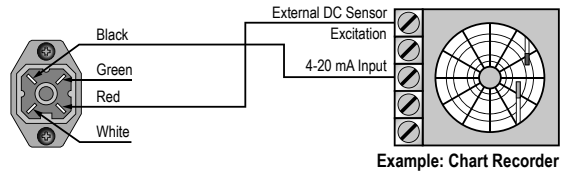

Schematic 1: 4-20 mA connection using target power supply

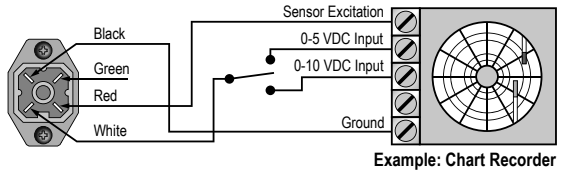

Schematic 2: 0-5 Vdc or 0-10 Vdc connection using target power supply

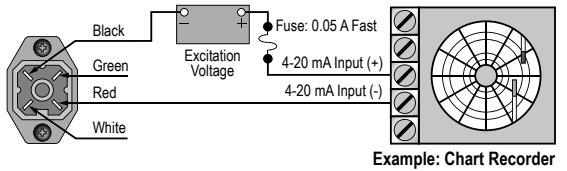

Schematic 3: 4-20 mA connection using target external power supply

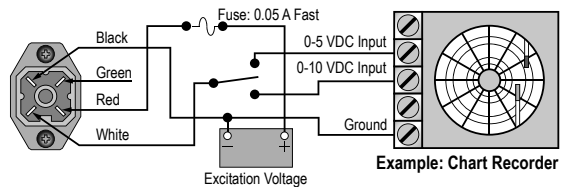

Schematic 4: 0-5 Vdc or 0-10 Vdc connection using target external power supply

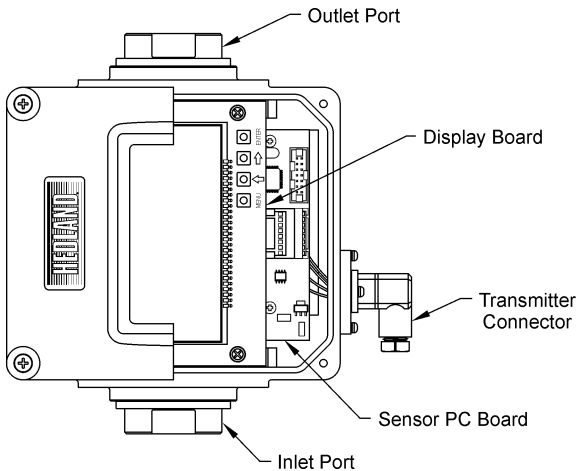

Figure 4 - Terminology

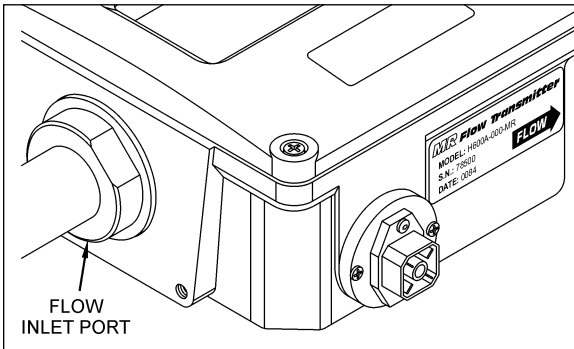

Figure 5 - Flow Direction Arrow

Installing the Transmitter

1. Disconnect the electrical power from the target system before making or changing any transmitter connections.
2. Use 0.05A fast acting fuse if non-current limited power sources are utilized.
3. Terminate cable shield connection at either DC ground or earth ground.
4. Mount the transmitter so fluid is traveling in the direction of the flow arrow. See **Figure 5**.
5. Install unit in desired location. Use wrench on transmitter flats to hold the unit in place during installation. DO NOT TURN the transmitter using the wrench. See **Figure 6**.
6. After installation, rotate transmitter by hand to view display. See **Figure 7**.
7. Capture the zero flow position on the meter cone using the ZERO CAPTURE procedure found on page 9.

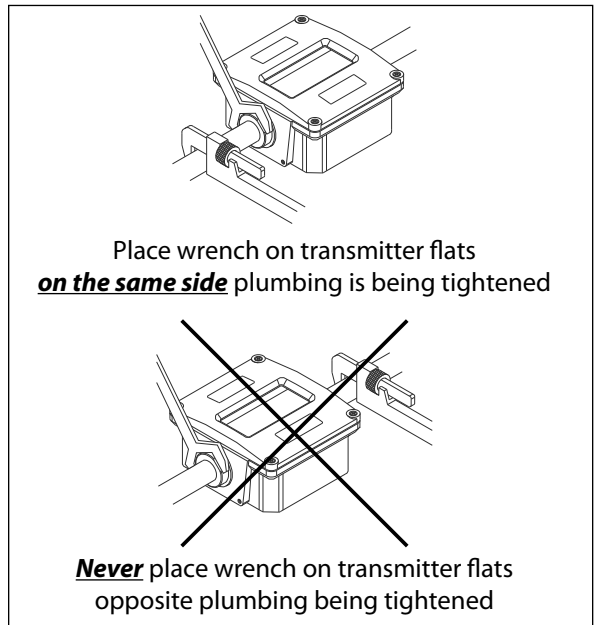

Figure 6 - Installing Meter

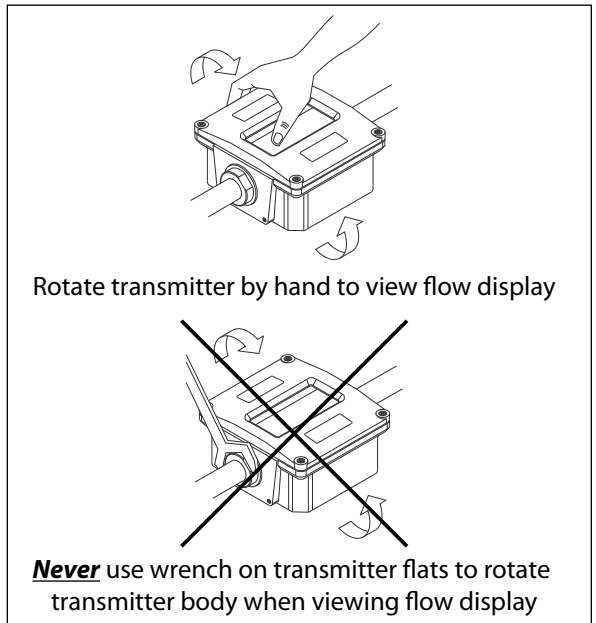

Figure 7 - Rotating Meter

IV. OPERATION

NOTE: Refer to the Appendix for application information and fluid charts.

Operating the Meter

The monitor has two modes of operation, referred to as RUN mode and PROGRAM mode as indicated on the display screen readout. Normal operation will be in the run mode. To access the program mode, press the MENU key until the first programming screen DISPLAY appears. (PROGRAM appears on left side of display.) After programming the meter, a password may be entered to prevent unauthorized access or changing of the setup features.

Normal Operation (RUN) Mode

During normal operation, the display will show RUN and the flow rate, total flow, or toggle back and forth between the two as defined by the DISPLAY configuration.

The four buttons have the following function in RUN mode:

MENU - Selects programming mode.

UP ARROW - No function.

RIGHT ARROW - No function.

ENTER - The current total can be manually stored in the monitor's flash memory. Press and hold the ENTER key for 2 seconds. The display will respond with a flashing TOTALSVD and then will return to RUN mode.

RESET TOTAL - To reset the monitor's total display, press the MENU and ENTER keys simultaneously until TOTALRST starts to flash. The TOTALRST will stop flashing and the display will return to RUN mode at the conclusion of the reset procedure.

Programming Operation (PROGRAM) Mode

The programming mode allows the user to change the configuration and adjust the calibration of the meter. The MR Flow Transmitter has two types of configuration changes in program mode:

- To view or change selections from a predefined list
- To view or change numeric entries

During programming operation, the following four button functions are provided:

MENU - Enters and exits programming mode.

Change to programming mode by pressing the MENU key once. The mode indicator on the display will change from RUN to PROGRAM.

UP ARROW - Use the UP ARROW key to scroll through the configuration choices in a bottom-to-top order. For numeric setup, this button increments numeric values.

RIGHT ARROW - Use the RIGHT ARROW key to scroll through the configuration choices in a top-to-bottom order. For numeric setup, this button moves the active digit to the right.

ENTER - Used to enter menus, to change configurations and to save programming information.

NOTE: If any input value exceeds the meter's capabilities, the LIMIT indicator will begin to flash indicating an invalid entry. Press ENTER once to return to the entry screen to reenter the value.

Cover Removal/Reinstallation

It is necessary to remove the MR Transmitter cover to access the programming keys. Use a Phillips screwdriver to remove the 4 screws that hold the cover in place, turning them counterclockwise. When programming is completed, reinstall the cover. To properly seat the built-in cover gasket, tighten the cover screws clockwise in a crisscross pattern as shown in **Figure 8** on page 8.

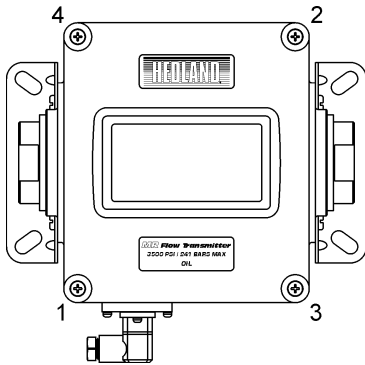

Figure 8 - Cover Screw Tightening Sequence

Programming Procedures

The MR Transmitter has been programmed at the factory according to the specifications that were provided at the time of order. No further programming is required unless a change has occurred in the original specifications.

If programming is required, the MR Transmitter allows two basic sets of programming procedures: List Item Selection and Numeric Value Entry.

List Item Selection Procedure

NOTE: If you are already in PROGRAM mode and the selection to be viewed or changed is already displayed, proceed to step 3 below. If you are in PROGRAM mode and the selection to be viewed or changed is not displayed, press the UP or RIGHT ARROW key and repeat pressing until the desired selection appears. Proceed to step 3.

1. Press MENU.

PROGRAM appears in the lower left-hand corner and DISPLAY appears.

2. Press the UP ARROW or RIGHT ARROW key to move to the desired selection.
3. Press ENTER to view the current selection.
- 4a. If the current selection is desired, press ENTER to confirm.

The unit will automatically advance.

- 4b. If current selection must change, press either arrow key to scroll through the available choices. Press ENTER to confirm your selection.

The unit will automatically advance.

5. To exit programming, press the MENU button.

The display will change to RUN mode.

Numeric Value Entry Procedure

NOTE: If you are already in PROGRAM mode and the desired selection is displayed, proceed to step 3 below. If you are in PROGRAM mode and the desired selection is not displayed, press the UP or RIGHT ARROW key and repeat pressing until the desired selection appears. Proceed to step 3.

1. Press MENU.

PROGRAM appears in the lower left-hand corner and DISPLAY appears.

2. Press the UP ARROW or RIGHT ARROW key to move to the desired selection.

The current numeric value for this selection appears in the upper section of the display.

- 3a. If the current displayed value is desired, press ENTER. The left most programmable number begins to flash. Press ENTER again to confirm and keep the current setting.

The unit will automatically advance.

- 3b. If the current selection must change, press ENTER. The left most programmable number begins to flash. Use the UP ARROW key to scroll through the digits 0-9 and change the flashing digit to the desired value. Use the RIGHT ARROW key to move the active digit to the right. Continue using the UP and RIGHT ARROW keys until all desired digits are selected.

4. Press ENTER to confirm your selection.

The unit will automatically advance.

5. To exit programming mode, press the MENU key.

The display will change to RUN mode.

Programming Flow Chart

The programming flow chart on pages 12 and 13 will aid understanding of the menu structure of the MR Flow Transmitter. It will also help with understanding the available configuration selections.

Basic Programming Descriptions

Display Mode

The meter can display RATE (flow rate) or TOTAL (total accumulated flow) or alternate between BOTH rate and total. Its displayed name is DISPLAY and is viewed or changed using the List Item Selection Procedure found on page 8.

Rate Units of Measure

The meter allows the selection of many common rate units. Its displayed name is RATE UNT and is viewed or changed using the List Item Selection Procedure found on page 8.

Rate (Time) Interval

The meter allows selection of several intervals based on time. Its displayed name is RATE INT and is viewed or changed using the List Item Selection Procedure found on page 8.

Total Units of Measure

If the total flow is being displayed, the units for the total must first be chosen. The monitor allows the choice of many common totalization units. Its displayed name is TOTL UNT and is viewed or changed using the List Item Selection Procedure found on page 8.

Total Display Multiplier

The meter has the ability to accumulate the flow total in multiples of ten. For example, if the most desirable totalization unit is 1,000 gallons, the monitor can easily be set up for this requirement. Once back in RUN mode every time the total display increments by one digit the actual total would be an additional 1,000 gallons. At 1,000 total gallons the total display would read 1, at 3,000 gallons the total display would read 3, etc. This feature allows the unit to accumulate totals

that would exceed the 8 digit display capacity. **Table 2** lists the available selection choices. Its displayed name is TOTL EXP and is viewed or changed using the List Item Selection Procedure found on page 8.

E-2	Total display number indicates increments of 0.01 unit
E-1	Total display number indicates increments of 0.1 unit
E0	Total display number indicates increments of 1 unit (Factory Default)
E1	Total display number indicates increments of 10 unit
E2	Total display number indicates increments of 100 unit
E3	Total display number indicates increments of 1,000 unit
E4	Total display number indicates increments of 10,000 unit
E5	Total display number indicates increments of 100,000 unit
E6	Total display number indicates increments of 1,000,000 unit

Table 2 - Total Flow Units

Full Flow Rate

The full flow rate is used to span the meter. Its displayed name is FULL FLOW and is viewed or changed using the Numeric Value Entry Procedure found on page 8.

Zero Capture

The zero position of the meter cone must be set when installing the meter. To capture the zero calibration position, press ENTER at the ZERO CAP prompt. NO will display. Press either arrow key to change to YES, then press ENTER to capture zero.

Viscosity Units - Displayed for OIL meters only

Viscosity Units is used in conjunction with Viscosity to perform viscosity correction for OIL applications. The meter allows the selection of the viscosity units, SUS

or cSt. Its displayed name is VIS UNIT and is viewed or changed using the List Item Selection Procedure found on page 8.

Viscosity - *Displayed for OIL meters only*

Viscosity is used in conjunction with Viscosity Units to perform viscosity correction for OIL applications. Enter the viscosity in either SUS or cSt, depending on the Viscosity Units selected, of the oil that will be used. Its displayed name is VISCOSTY and is viewed or changed using the Numeric Value Entry Procedure found on page 8.

Operating Pressure Units - *Displayed for GAS meters only*

Operating Pressure Units is used in conjunction with Operating Pressure in GAS applications to compensate for the actual pressure being measured at the meter. The meter allows the selection of the operating pressure units, Bar or PSI. Its displayed name is PRESUNIT and viewed or changed using the List Item Selection Procedure found on page 8.

Operating Pressure - *Displayed for GAS meters only*

Operating Pressure is used in conjunction with Operating Pressure Units in GAS applications to compensate for the actual pressure being measured at the meter. Enter the operating pressure in either Bar or PSI units, depending on the Operating Pressure Units selected. Its displayed name is OP PRES and is viewed or changed using the Numeric Value Entry Procedure found on page 8.

Operating Temperature Units - *Displayed for GAS meters only*

Operating Temperature Units is used in conjunction with Operating Temperature in GAS applications to compensate for the actual temperature of the gas being measured at the meter. The meter allows the selection of the operating temperature units, °F or °C. Its displayed name is TMP UNIT and is viewed or changed using the List Item Selection Procedure found on page 8.

Operating Temperature - *Displayed for GAS meters only*

Operating Temperature is used in conjunction with

Operating Temperature Units in GAS applications to compensate for the actual temperature of the gas being measured at the meter. Enter the operating temperature in either °F or °C, depending on the Operating Temperature Units selected. Its displayed name is OP TEMP and is viewed or changed using the Numeric Value Entry Procedure found on page 8.

Specific Gravity Correction Factor

Specific Gravity is used to compensate for the specific gravity of the LIQUID or GAS being measured with the meter. Its displayed name is SP GRAV and is viewed or changed using the Numeric Value Entry Procedure found on page 8.

Damping

The Damping factor is increased to enhance the stability of the flow readings. Damping values are decreased to allow the flow meter to react faster to changing values of flow. This parameter can range from 0 to 99; factory default is 0. Its displayed name is DAMPING and is viewed or changed using the Numeric Value Entry Procedure found on page 8.

Output Mode

The MR Flow Transmitter offers three analog output modes:

- 4-20 mA Output Signal
- 0-5 Volts DC Output Signal
- 0-10 Volts DC Output Signal

The output mode selected is determined by the type of peripheral device being connected to the MR Flow Transmitter.

The displayed name is OUT MODE and is viewed or changed using the List Item Selection Procedure found on page 8.

NOTE: *Setup prompts and descriptors for configuring and calibrating the analog output will correspond to the output mode selected. Refer to the Flow Chart on pages 12 and 13.*

Password

Password protection prevents unauthorized users from changing programming information. Initially

the password is set to all zeros. Its displayed name is PASSWORD and is viewed or changed using the Numeric Value Entry Procedure found on page 8.

Restore Defaults

This feature allows you to restore factory calibration data. Its displayed name is RES DFLT. To restore factory calibration data, select YES, then press ENTER.

Advanced Programming Descriptions

Advanced Programming allows the user access to reconfigure the Analog Output. Calibration of the Analog Output is preset at the factory, but can be changed to customize calibration for your installation.

To access the Advanced Programming Options, press and hold the MENU button for approximately 3 seconds until DISPLAY is viewed on the display panel. The programming menus will begin with Display Mode (DISPLAY) and continue as described above through Output Mode (OUT MODE).

After Output Mode has been entered, Advanced Programming starts with the following:

Calibration of Analog Output

This selection allows access to the calibration and testing of the analog output signal.

To test or change the analog output calibration, it is first necessary to change the default setting for CAL OUT? from NO to YES.

NOTE: Setup prompts and descriptors for configuring and calibrating the analog output will correspond to the output mode selected. Refer to the Flow Chart on page 13.

1. At the CAL OUT? prompt press ENTER. NO will display.
2. To change to YES, press either arrow key.
3. The analog output will go to its minimum output level. A numeric value between 0-4000 will display. This is an internal number used to drive the analog output.

4. To increase the analog output signal level, press the UP ARROW key. To decrease the analog output signal level, press the RIGHT ARROW key.
5. Press ENTER to store the setting.
6. The analog output will go to its maximum output level. A numeric value between 0-4000 will display. This is an internal number used to drive the analog output.
7. To increase the analog output signal level, press the UP ARROW key. To decrease the analog output signal level, press the RIGHT ARROW key.
8. Press ENTER to store the setting.
9. The unit will advance to the analog output test mode. The analog output will go to its minimum output level. A numeric value of 0 will display. For test purposes, the analog output signal can be run up or down in increments of 1 milliamp or 1 volt, depending on the OUT MODE selected.
10. To increase the analog output signal level, press the UP ARROW key. To decrease the analog output signal level, press the RIGHT ARROW key.
11. Press ENTER to exit the analog calibration mode.
12. The unit automatically advances to the PASSWORD feature.

Password

Password protection prevents unauthorized users from changing programming information. Initially the password is set to all zeros. Its displayed name is PASSWORD and is viewed or changed using the Numeric Value Entry Procedure found on page 8.

Restore Defaults

This feature allows you to restore factory calibration data. Its displayed name is RES DFLT. To restore factory calibration data, select YES, then press ENTER.

General Operations - Basic Programming For Software Version 10.1

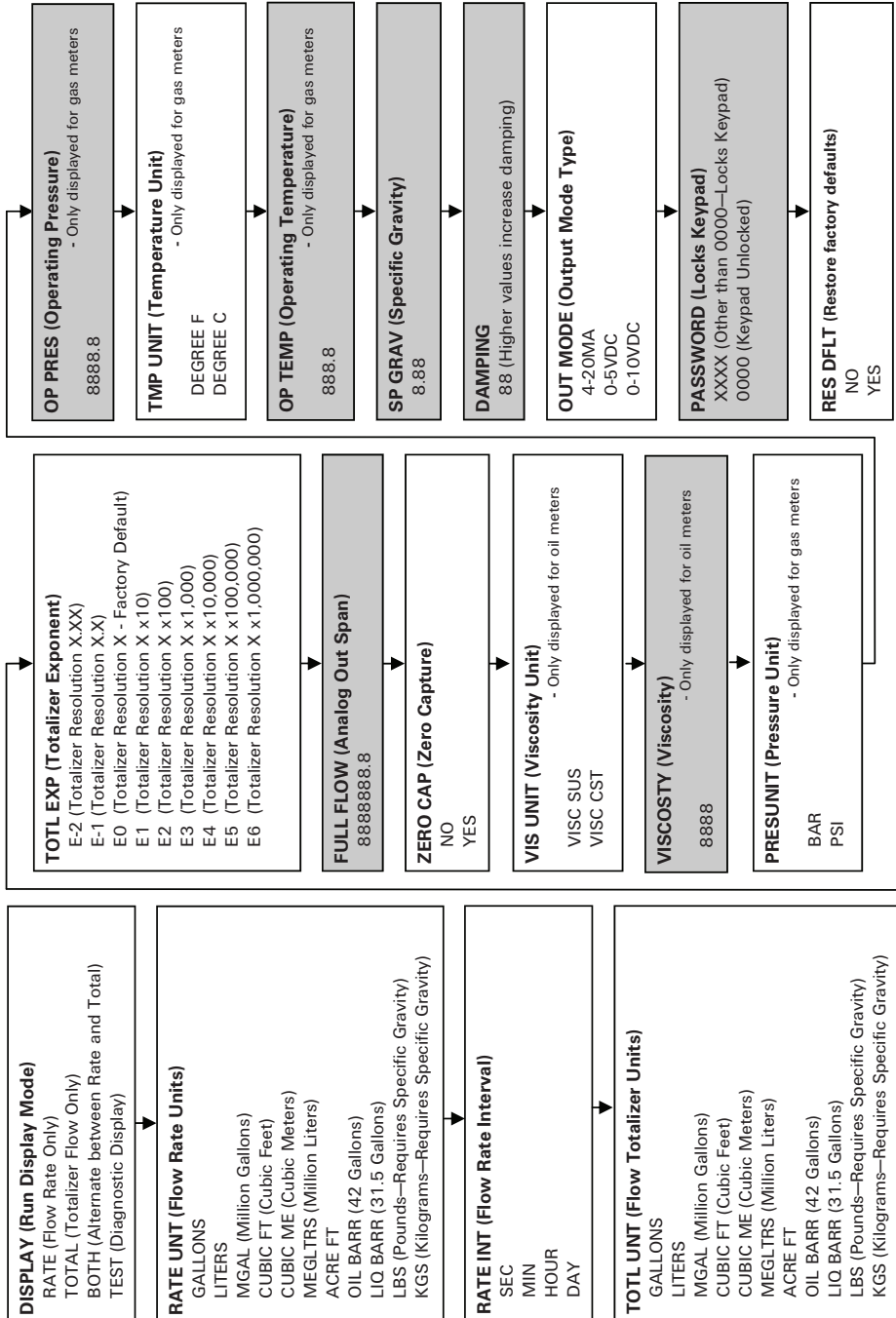

NOTE:
Shaded boxes indicate Numeric Value Entries
Unshaded boxes indicate List Item Entries

General Operations - Advanced Programming

To access the Advanced Programming Menu press and hold the Menu button for approximately 3 seconds until DISPLAY is viewed on the display.

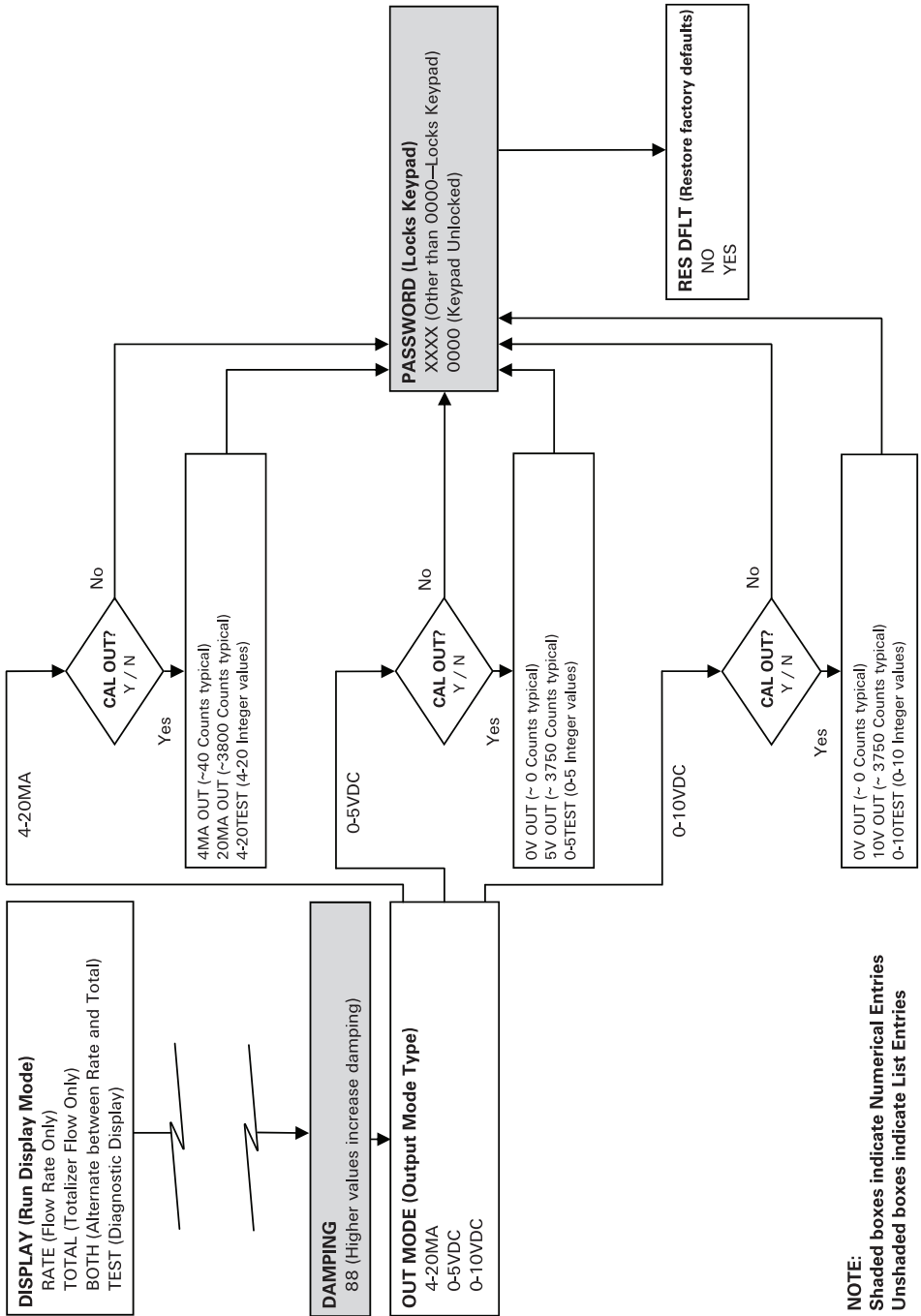

NOTE:
Shaded boxes indicate Numerical Entries
Unshaded boxes indicate List Entries

V. MAINTENANCE



WARNING

Disconnect electrical power before removing meter cover. Failure to follow these instructions could result in serious personal injury or death and/or damage to the equipment.



WARNING

Before attempting to remove the transmitter from the line, check the system to confirm that line pressure has been reduced to zero PSI. Failure to follow these instructions could result in serious personal injury or death and/or damage to the equipment.

Cartridge Cleaning (Figure 4 on page 5 and Figure 9 on page 15)

1. Disconnect the transmitter cable.
2. Remove the meter from the line. Remove excess piping from the transmitter.

NOTE: It is not necessary to remove the aluminum housing from the transmitter to remove it from the line.

3. Thoroughly wipe off the entire transmitter surface using mild detergent or isopropyl alcohol.



CAUTION

Do not use aromatic hydrocarbons, halogenated hydrocarbons, ketones or ester based fluids on polycarbonate lens. Failure to follow these instructions could result in damage to the transmitter.

4. Remove the inlet port cap, wave spring, retaining ring, and cone assembly from the transmitter body (Figure 9 on page 15).
5. Gently push the body towards the outlet port.

6. The piston, inner magnet and transmitter spring are secured within the transmitter body with a retaining ring. Remove the retaining ring with a small screwdriver, then the internal components can be removed from the body (Figure 9 on page 15).

NOTE: If internal parts do not slide freely from cartridge, use a wooden dowel inserted into the outlet port of the meter to push parts out.

7. Place all parts on a clean work surface. Clean and inspect all parts. Replace any that appear worn or damaged.

Check inlet port O-ring for damage and replace if required.



CAUTION

Field replacement of the spring, metering cone and/or piston/magnet assembly may result in changes to the calibration of the flow meter.

8. Reassemble the transmitter by inserting the transmitter spring into the body, followed by the piston/inner magnet assembly. A slight compression of the piston against the spring is required during installation of the retaining ring.
9. Gently push body assembly into the outlet end of the transmitter enclosure. The flat surface of the body output port should be flush with the transmitter enclosure opening.
10. With the transmitter positioned vertically on a flat surface, inlet port facing up, install the transmitter cone assembly and wave spring into the body and secure with the inlet port end cap.
11. Reinstall transmitter to the line. Reconnect electrical power.

Inspection

1. Frequent inspection should be made. The environment and frequency of use should

determine a schedule for maintenance checks. It is recommended that it should be at least once a year.

2. Perform visual, electrical, and mechanical checks on all components on a regular basis.
3. Visually check for undue heating evidence such as discoloration of wires or other components, damaged or worn parts, or leakage evidence such as water or corrosion in the interior.
4. Electrically check to make sure that all connections are clean and tight and that the device is wired properly.

VI. TROUBLESHOOTING

No LCD display

- For 4-20 mA operation, check for current flow in the loop.

- Check polarity of the current loop connections for proper orientation.
- For 0-5 V or 0-10 V operation, check for proper voltage being supplied to the unit.
- Check polarity of the supply voltage.

No rate or total displayed

- Check flow meter body and internal components for debris. Piston should move inside the tube freely.
- Check setup programming of flow meter.

Unstable Flow Reading

- This usually indicates pulsing or oscillation in the actual flow. Increase the DAMPING parameter to increase the filtering in order to provide a more stable display reading.

VI. APPENDIX

Application Information - Liquid

Viscosity Effect (SUS/cSt)

The design utilizes a precision machined, sharp-edged orifice and biasing calibration spring that assures operating stability and accuracy over the wide viscosity range common to many fluids. Generally, high flow models of each meter size provide good accuracy over a viscosity range of 40 to 500 SUS (4.2 to 109 cSt).

Density Effect (specific gravity)

Any fluid density change from stated standards has a proportional effect on meter accuracy. Corrections for more or less dense fluids can be made to standard scales using the following correction factor:

$$\sqrt{\frac{1.0}{\text{Specific Gravity}}} \quad \text{for water/water-based meters}$$

$$\sqrt{\frac{0.876}{\text{Specific Gravity}}} \quad \text{for petroleum-based meters}$$

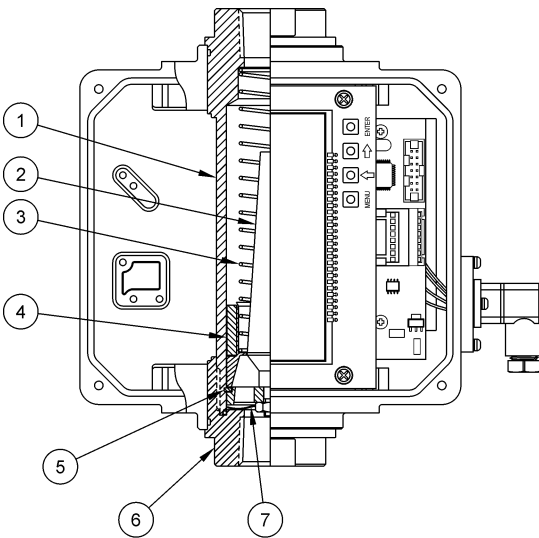

1. BODY
2. CONE ASSEMBLY
3. METER SPRING
4. PISTON ASSEMBLY
5. RETAINING RING
6. CAP
7. WAVE SPRING

Figure 9 - Cartridge Components

Application Information - Pneumatic

NOTE: Pressure and temperature readings must be taken at the flow meter inlet to ensure accurate correction factors.

The pneumatic flow meter is calibrated for air in standard cubic feet per minute (scfm) at 1.0 s.g. (70 °F @ 100 psi), and liter per second (lps) at 1.0 s.g. (21 °C @ 6.9 bar).

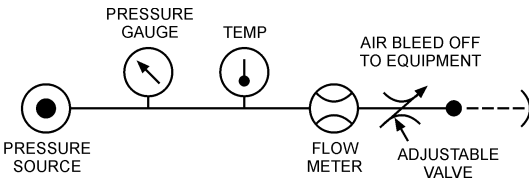

Figure 10 - System Schematic

FLUID SELECTION CHART	Specific Gravity	Correction Factor Std. Scale	Material									
			Aluminum	Brass	T316 SST	T303 SST	Viton®	EPR	Polycarbonate	Nylon	Pyrex®	
Air	1.0	1.000	R	R	R	R	R	R	R	R	R	
Argon(A)	1.38	1.175	R	R	R	R	R	R	R	R	R	
Carbon Dioxide(CO ₂)	1.53	1.237	R	R	R	R	R	R	R	R	R	
Freon 11 (CCl ₃ F)	4.92	2.218	R	R	R	R	R	R	R	R	R	
Freon 12 (CCl ₂ F)	4.26	2.060	R	R	R	R	R	R	R	R	R	
Helium(HE)	0.14	0.374	R	R	R	R	R	R	R	R	R	
Hydrogen (H ₂)	0.07	0.265	R	R	R	R	R	R	R	R	R	
Natural Gas	0.60	0.775	C	C	R	C	R	N	C	R	R	
Nitrogen (N ₂)	0.97	0.985	C	C	R	R	R	R	C	R	R	
Oxygen (O ₂)	1.10	1.049	R	R	R	R	R	R	R	R	R	
Propane (C ₃ H ₈)	1.57	1.253	R	R	R	R	R	N	N	R	R	

R = Recommended
N = Not recommended
C = Consult Factory

Table 5 - Fluid Selection Chart

DETERMINE FLOW RATES USING DIFFERENT PRESSURES & TEMPERATURES										
$\text{scfm (actual)} = \frac{\text{scfm (indicated)}}{f_1 \times f_2 \times f_3}$ Where f_1 = Conversion factor for inlet pressure f_2 = Conversion factor for temperature f_3 = Conversion factor for specific gravity										
TABLE 1 PRESSURE CORRECTION FACTOR (f_1) Operating Pressure										
psig	25	50	75	100	125	150	175	200	225	250
BAR	1.7	3.5	5.2	6.9	8.6	10.4	12.1	13.8	15.5	17.2
kPa	172	345	517	689	862	1034	1207	1379	1551	1724
f_1	1.700	1.331	1.131	1.00	.902	.835	.778	.731	.692	.658
$f_1 = \sqrt{\frac{114.7}{14.7 + \text{psig}}}$ $f_1 = \sqrt{\frac{7.914}{1.014 + \text{BAR}}}$ $f_1 = \sqrt{\frac{790.857}{101.357 + \text{kPa}}}$										
TABLE 2 TEMPERATURE CORRECTION FACTOR (f_2)										
°F	+10	+30	+50	+70	+90	+110	+130	+150	+170	+190
°C	-12.2	-1.1	+9.9	+21.0	+32.1	+43	+54	+65	+76	+88
f_2	.942	.962	.981	1.00	1.018	1.037	1.055	1.072	1.090	1.107
$f_2 = \sqrt{\frac{460 + \text{°F}}{530}}$ $f_2 = \sqrt{\frac{273 + \text{°C}}{293}}$										
TABLE 3 SPECIFIC GRAVITY CORRECTION FACTOR (f_3)										
$f_3 = \sqrt{\text{Sp. Gr.}}$										

Table 4 - Conversion Factors

NOTE: Table 4 is included to show the correction algorithms include in the program to perform pressure, temperature, and specific gravity corrections. When configuring the MR Flow Transmitter, enter the actual operating pressure, temperature, and specific gravity values, not the correction factors.

Flow vs. Pressure Drop *

Petroleum Fluids

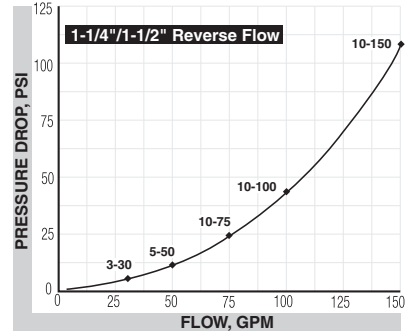
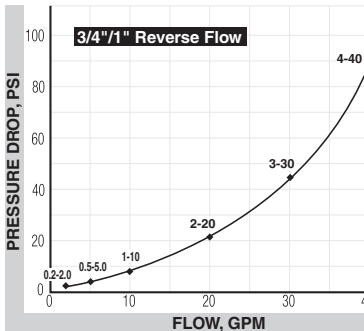
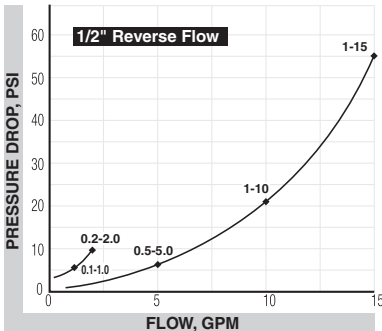
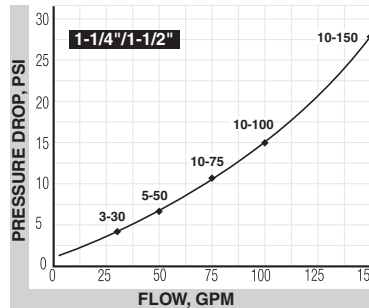
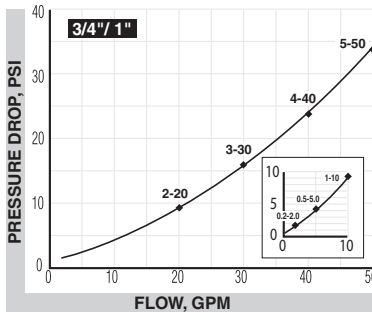
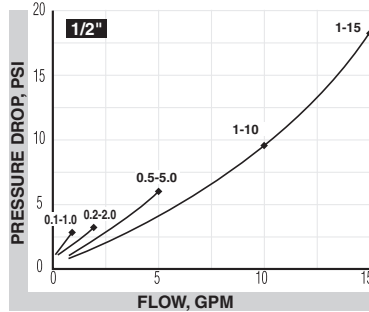
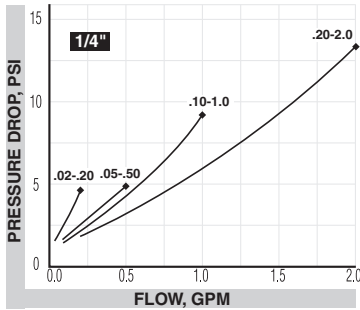

- * 1. The pressure drop curves are valid for fluids with density and viscosity similar to factory test fluids. Fluids, especially with higher viscosity than these test fluids, will yield a higher pressure drop through the flow meter and piping system per a given flow volume.
- 2. A system must have adequate fluidic horsepower available to move the system fluid at a prescribed rate at a pressure adequate to overcome all pressure reducing devices – including the flow meter.

Phosphate Ester

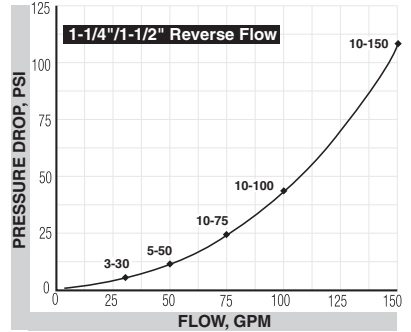
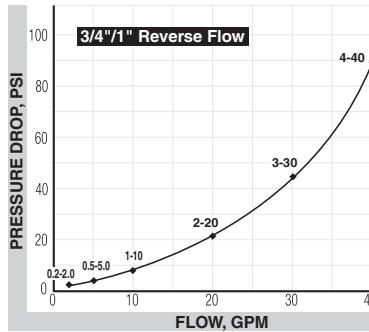
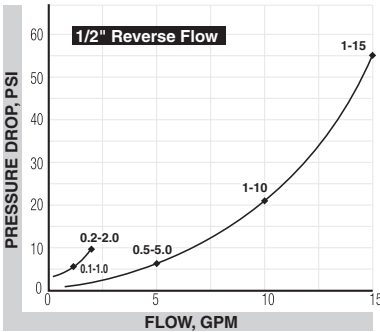
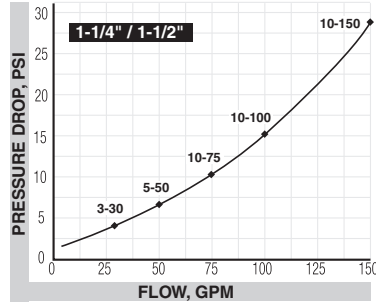
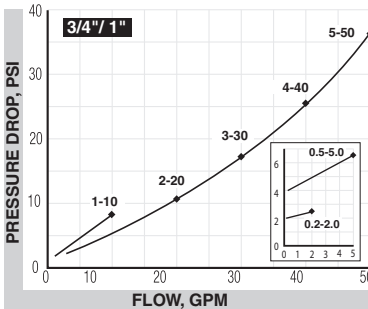
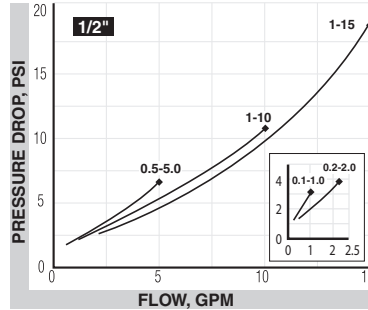
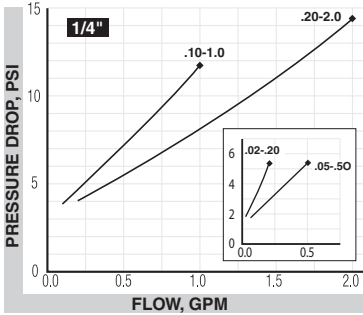

A.P.I. Oil

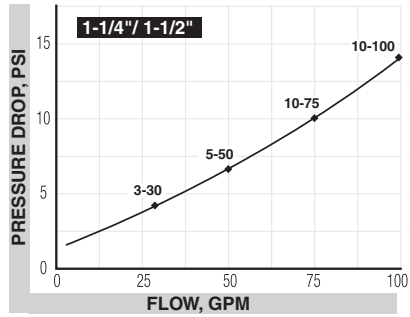
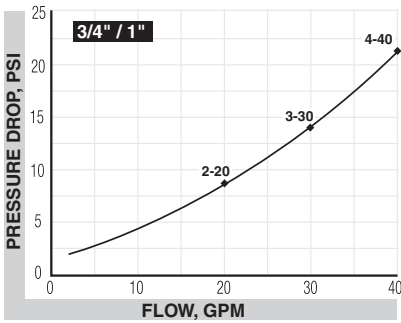
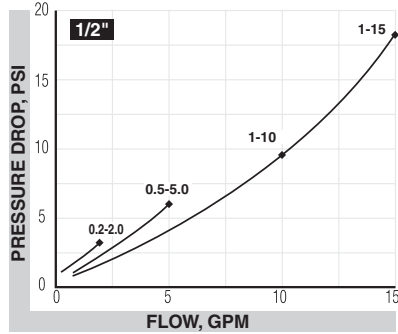
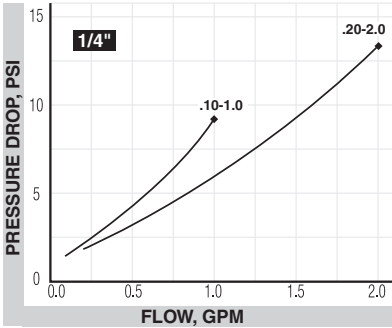

Water-based Fluids

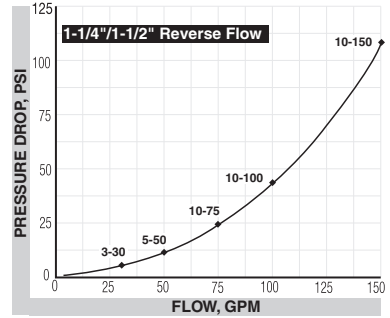
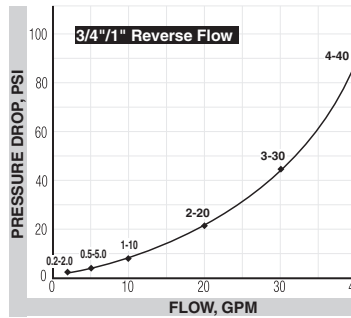
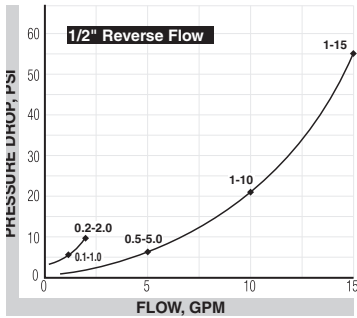
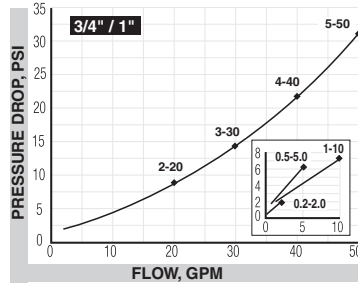
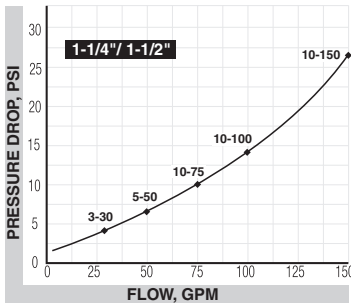
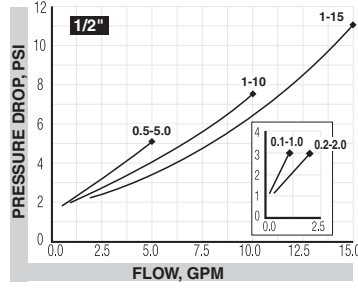
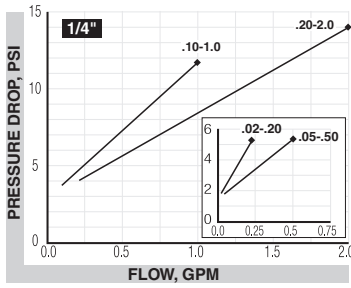

Water

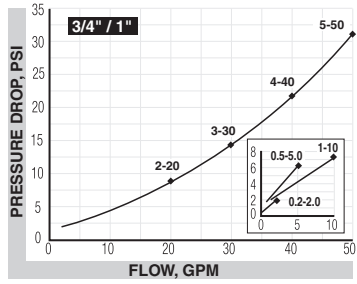
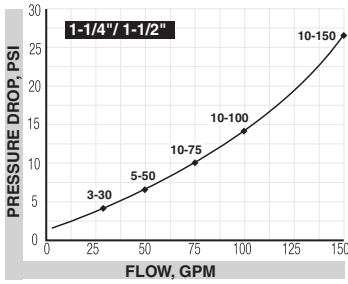
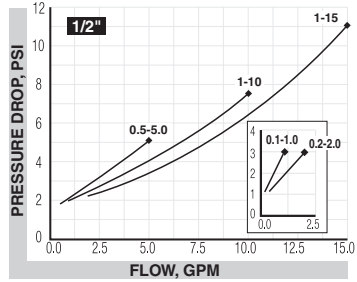
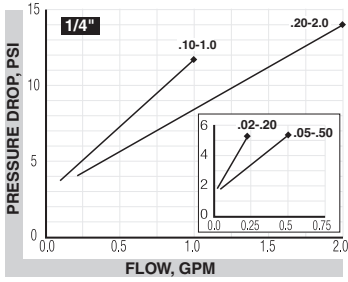

Caustic and Corrosive Liquids

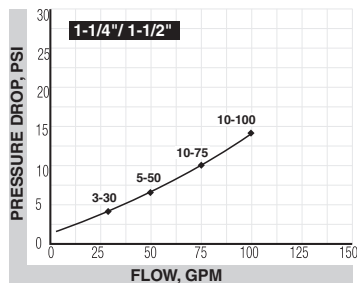
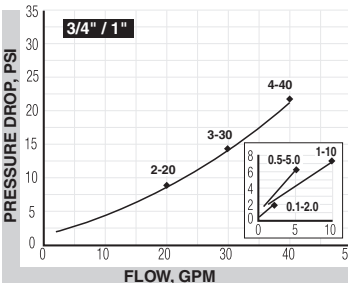
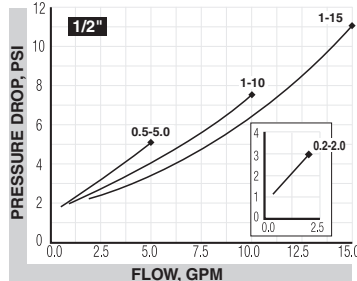
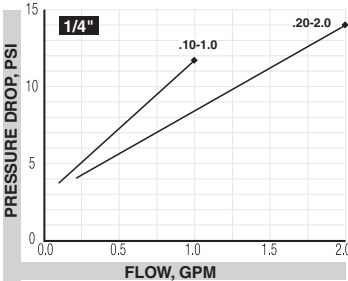

Air / Compressed Gases

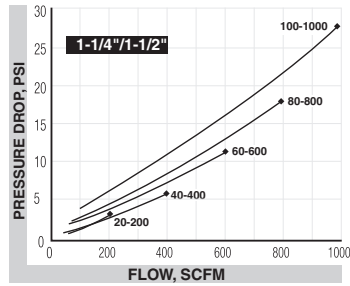
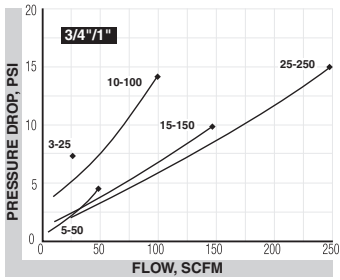
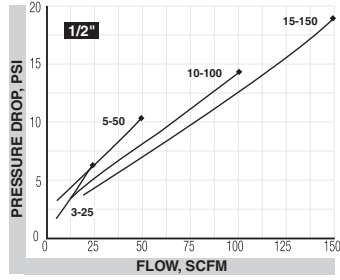
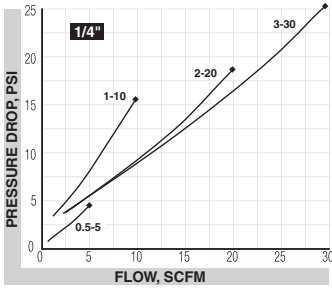

Air / Caustic and Corrosive Gases

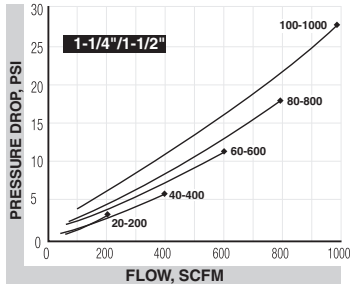
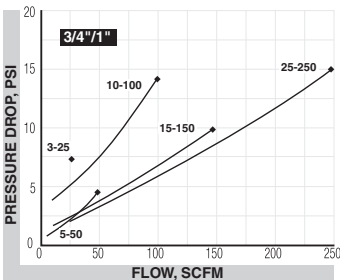
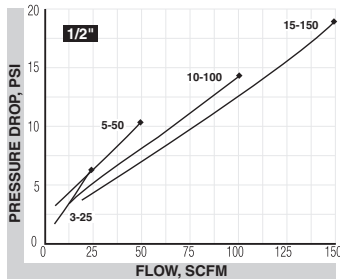
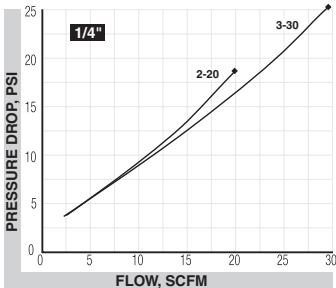

Dimensions

A Nominal Port Size	B Length in. (mm)	C Length in. (mm)	D Length in. (mm)	E Width in. (mm)	F Width in. (mm)	G Width in. (mm)	H Width in. (mm)	I Depth in. (mm)	J Offset in. (mm)	K Hole Dia. in. (mm)
¼ (SAE 6)	6.60 (168)	5.27 (134)	6.41 (163)	6.00 (152)	3.23 (82)	3.00 (76)	4.20 (107)	2.94 (75)	1.51 (38)	.31 (8)
½ (SAE 10)	6.60 (168)	5.27 (134)	6.41 (163)	6.00 (152)	3.23 (82)	3.00 (76)	4.20 (107)	2.94 (75)	1.51 (38)	.31 (8)
¾ (SAE 12)	7.20 (183)	5.27 (134)	7.04 (179)	6.00 (152)	3.60 (91)	3.00 (76)	4.20 (107)	2.94 (75)	1.27 (32)	.31 (8)
1 (SAE 16)	7.20 (183)	5.27 (134)	7.04 (179)	6.00 (152)	3.60 (91)	3.00 (76)	4.20 (107)	2.94 (75)	1.27 (32)	.31 (8)
1-¼ (SAE 20)	12.20 (310)	10.68 (271)	11.65 (296)	7.63 (194)	4.84 (123)	3.82 (97)	5.02 (128)	4.50 (114)	2.20 (56)	.31 (8)
1-½ (SAE 24)	12.20 (310)	10.68 (271)	11.65 (296)	7.63 (194)	4.84 (123)	3.82 (97)	5.02 (128)	4.50 (114)	2.20 (56)	.31 (8)

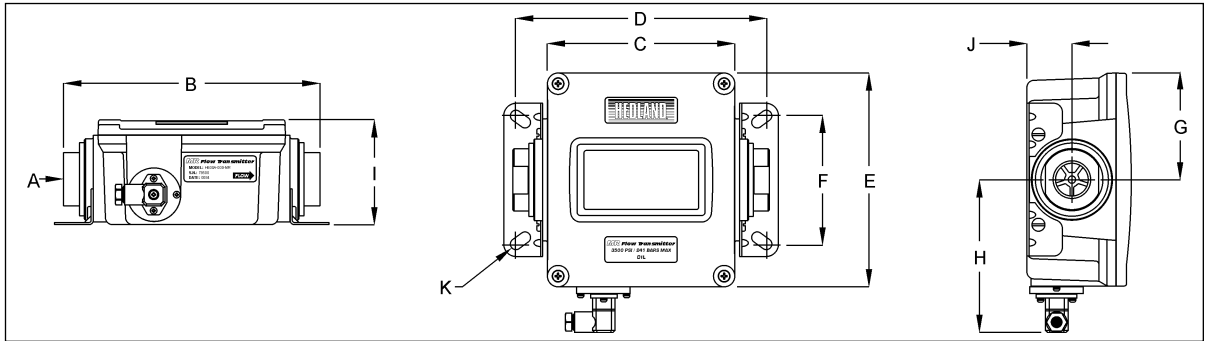

Return Goods Authorization

When returning equipment for service, a Returned Goods Authorization (RGA) number must be obtained from our Service Department. Please contact them by phone at 800-433-5263 or 262-639-6770 or by e-mail to hedlandsales@racinefed.com.

All returns go to the following address and must include the RGA number on the outside of the box:

Hedland
Division of Racine Federated Inc.
8635 Washington Avenue
Racine, WI 53406-3738 USA
Attn: RGA # xxx-xxxx

Waste Electrical and Electronic Equipment (WEEE) Directive



In the European Union, this label indicates that this product should not be disposed of with household waste. It should be deposited at an appropriate facility to enable recovery and recycling.

For information on how to recycle this product responsibly in your country, please visit:

www.racinefed.com/recycle/

LIMITED WARRANTY and DISCLAIMER

Hedland, Division of Racine Federated Inc. warrants to the end purchaser, for a period of one year from the date of shipment from the factory, that all flow meters manufactured by it are free from defects in materials and workmanship. This warranty does not cover products that have been damaged due to misapplication, abuse, lack of maintenance, or improper installation. Hedland's obligation under this warranty is limited to the repair or replacement of a defective product, at no charge to the end purchaser, if the product is inspected by Hedland and found to be defective. Repair or replacement is at Hedland's discretion. A returned goods authorization (RGA) number must be obtained from Hedland before any product may be returned for warranty repair or replacement. The product must be thoroughly cleaned and any process chemicals removed before it will be accepted for return.

The purchaser must determine the applicability of the product for its desired use and assumes all risks in connection therewith. Hedland assumes no responsibility or liability for any omissions or errors in connection with the use of its products. Hedland will under no circumstances be liable for any incidental, consequential, contingent or special damages or loss to any person or property arising out of the failure of any product, component or accessory.

All expressed or implied warranties, including **the implied warranty of merchantability and the implied warranty of fitness for a particular purpose or application are expressly disclaimed** and shall not apply to any products sold or services rendered by Hedland.

The above warranty supersedes and is in lieu of all other warranties, either expressed or implied and all other obligations or liabilities. No agent or representative has any authority to alter the terms of this warranty in any way.



HEDLAND®

DIVISION OF RACINE FEDERATED INC.

8635 Washington Avenue, Racine, WI 53406-3738

Telephone: 262-639-6770 or 800-HEDLAND

Fax: 262-639-2267 or 800-CHK-FLOW

www.hedland.com hedlandtechhelp@racinefed.com

Materials & specifications are subject to change without notice.

HEDLAND is a registered trademark of Racine Federated Inc.

VITON is a registered trademark of DuPont Dow Elastomers.

TEFLON is a registered trademark of E.I. du Pont de Nemours and Company.

PYREX is a registered trademark of Corning Glass Works Corporation.

LOCTITE is a registered trademark of Henkel Loctite Corporation.

NATIONAL ELECTRICAL CODE is a registered trademark of NFPA.

UL is a registered trademark of Underwriters Laboratories.